

Mission: Robotics Expedition Kit

WALKER

1 ● ○ ○ ○

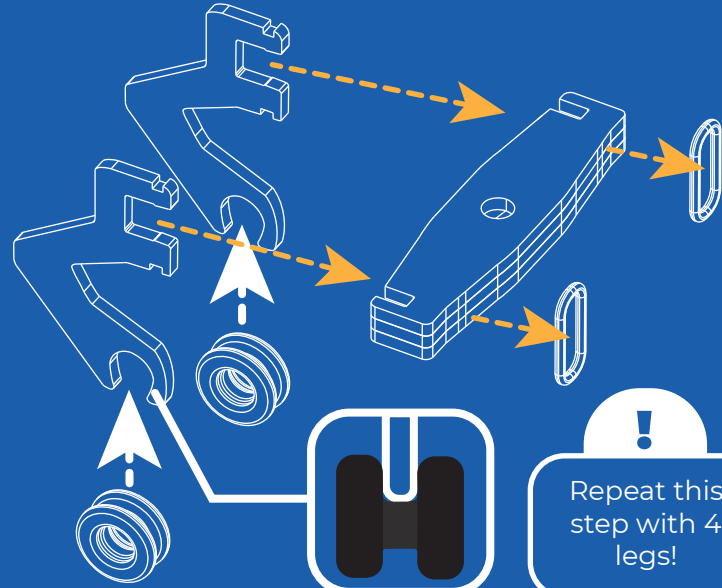

Repeat this step with 4 legs!

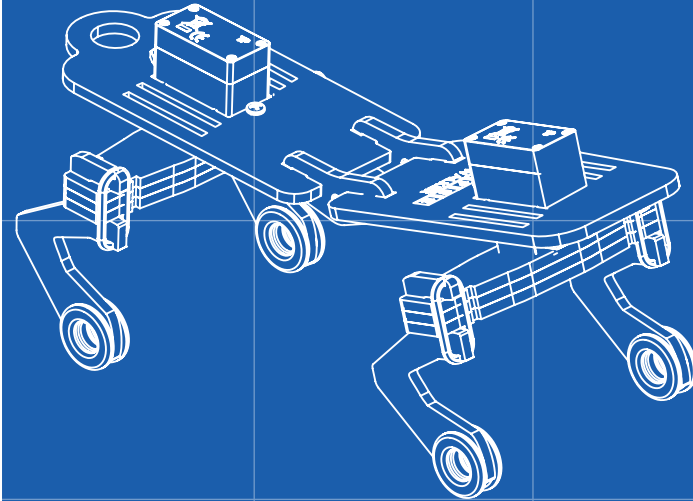

After assembly, head to MAKE.PLAYPIPER.COM to get started with your Walker and Rover!

1 ● ○

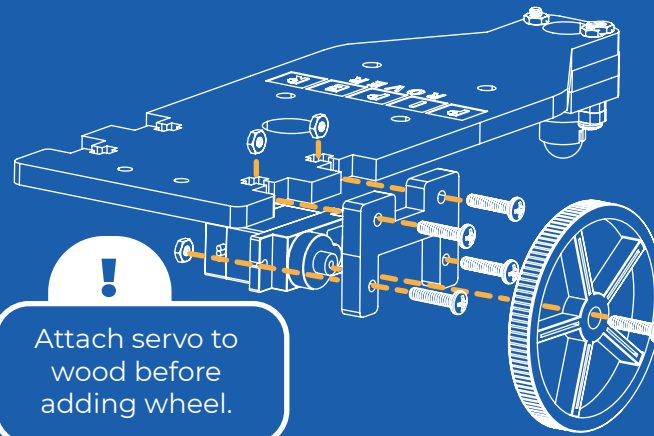

ROVER

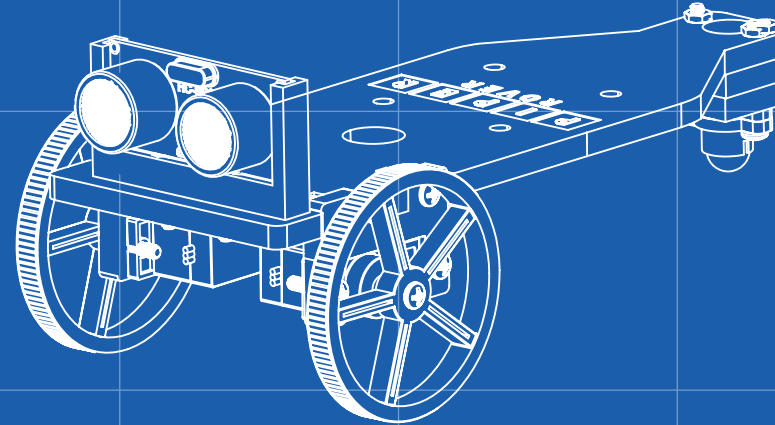

2 ● ●

NOTE

Make sure the ball fits into the holder before screwing in.

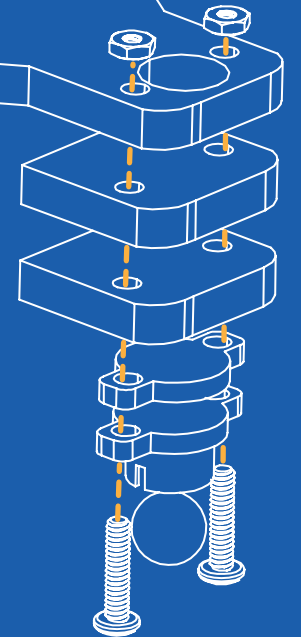

2 ● ● ○

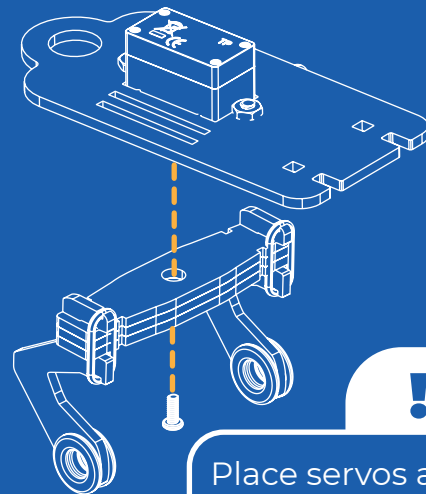
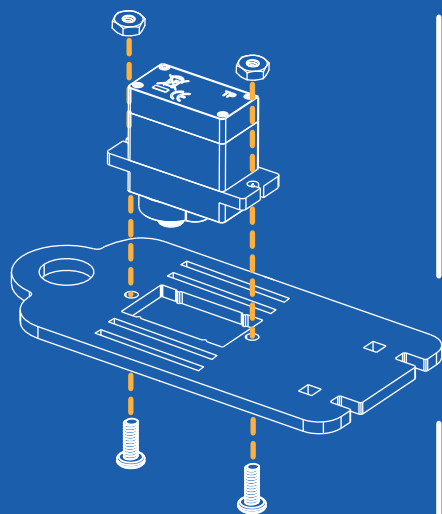

Place servos away from center.

3 ● ● ●

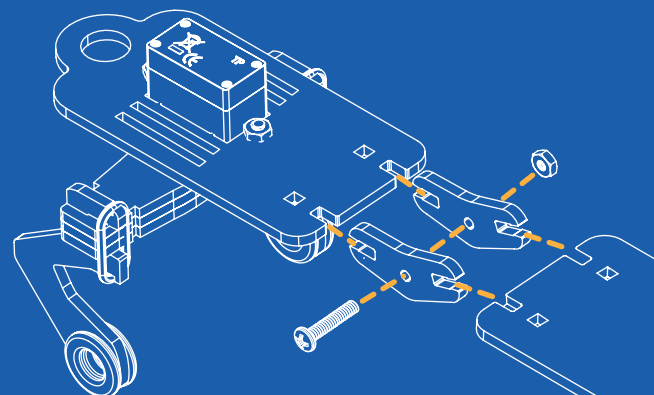

Do not overtighten the screw!

CUSTOMIZATIONS

The **Ultrasonic Range Finder** and **3D printed holder** can be attached to either your Walker or Rover!

WALKER

Add coins to your Walker!

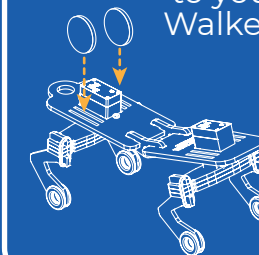

ROVER

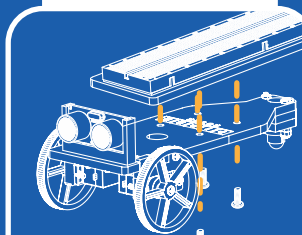

Attach your Starter Base to your Rover

